

Low Cost Linear Power Supplies



- ◆ Low Output Ripple
- ◆ Single and Multiple Outputs
- ◆ Excellent Line & Load Regulation
- ◆ Worldwide Voltage Taps

RoHS

Key Market Segments & Applications

Test & Measurement Burn-in & Test, Automated
 Test, Instrumentation,
 Measurement, Detection

Low noise applications
 Light Industrial

H Features and Benefits

Feature	Benefit
◆ Industry standard footprint	◆ Availability to second source
◆ Low Output Ripple	◆ Reduced system interference
◆ Tight regulation	◆ Better performance in sensitive equipment
◆ Operation up to 70C Ambients	◆ Easier system integration

Specifications

ITEMS		
AC Input	-	100/120/220/230/240VAC, 47-63Hz (derate by 10% for 50Hz operation)
Efficiency	-	5V: 45%, 12/15V: 55%, 24V: 60%
Transient Response	-	50us for 50% load change
EMI	-	FCC Class B, VDE0871 Level B
Output Adjustment	-	±5% for all outputs (except outputs 2 & 3 on triple output models)
Remote Sense	-	On all single output models, HDC12 & HDC15, and output 1 of triple output models
Line Regulation	-	±0.05% for 10% line change
Load Regulation	-	±0.05% for 50% load change
Ripple and Noise	-	<3mV peak to peak
Overcurrent Protection	-	Foldback with automatic recovery (Contact factory before adjusting)
Overvoltage Protection	-	Standard on 5V outputs set at 6.2V ±0.4V OVP12 module sold separately for other outputs (see model selector)
Cooling	-	Convection or forced air
Operating Temp. Range	-	0 to +70°C, derate 3%/°C above 50°C
Storage Temperature	°C	-55 to +85°C
Temperature coefficient	-	±0.01% per °C
Humidity	-	5 - 95% RH (non condensing)
Leakage Current	uA	<50uA
Vibration	-	MIL-STD-810C, Method 514
Shock	-	MIL-STD-810C, Method 516
Safety Agency Approval	-	UL60950-1, EN60950-1, CE Mark
Size	-	Please see outline drawings
Warranty	-	Two years

Note: See Installation Manual for full details, test methods of parameters and application notes

Output Ratings

	Model	Output	Output (V)	Max Current (A)	Power (W)
Single Output	HSB5-3-OVP	V1	5	3.0	15.0
	HSC5-6-OVP	V1	5	6.0	30.0
	HSN5-9-OVP	V1	5	9.0	45.0
	HSD5-12-OVP	V1	5	12.0	60.0
	HSB12-1.7	V1	12	1.7	20.4
	HSC12-3.4	V1	12	3.4	40.8
	HSN12-5.1	V1	12	5.1	61.2
	HSB15-1.5	V1	15	1.5	22.5
	HSC15-3	V1	15	3.0	45.0
	HSN15-4.5	V1	15	4.5	67.5
	HSB24-1.2	V1	24	1.2	28.8
	HSC24-2.4	V1	24	2.4	57.6
	HSN24-3.6	V1	24	3.6	86.4
	HSD24-4.8	V1	24	4.8	115.2
	HSB28-1.0	V1	28	1.0	28.0
	HSC28-2.0	V1	28	2.0	56.0
HSN28-3.0	V1	28	3.0	84.0	
HSD28-4.0	V1	28	4.0	112.0	
Dual Output	HDA12-15	V1	+12/15	1.0/0.8	24.0
		V2	-12/15	1.0/0.8	
	HDB12-15	V1	+12/15	1.8/1.5	40.0
		V2	-12/15	1.8/1.5	
HDC12	V1	12*	3.4	80.0	
	V2	12*	3.4		
HDC15	V1	15*	3.0	80.0	
	V2	15*	3.0		
Triple Output	HTC1	V1	5*	3.0	40.0
		V2	+12/15	1.0/0.8	
		V3	-12/15	1.0/0.8	
HTD1	V1	5*	6.0	70.0	
	V2	+12/15	1.7/1.5		
	V3	-12/15	1.7/1.5		
Accessories	OVP12 Adjustable 6.2-34V, 8A continuous, 12A peak				

* Isolated Outputs

Other Lambda Industrial Products

HWS	15 to 1800W single output (switching)
NNS	15 to 90W high reliability (linear)
ZWS	5 to 150W single output, universal input (switching)
VSB & VSC	10 to 150W single output, 115VAC input (switching)

H Outline Drawing

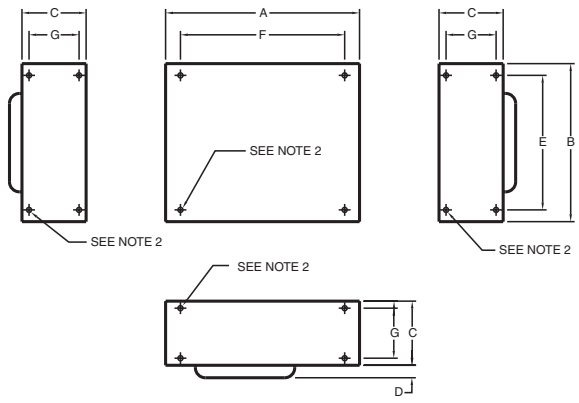

DIMENSIONS:								WEIGHT:	
MODEL	A	B	C	D	E	F	G	MODEL	LBS
HSB A	4.881 (124.0)	3.976 (101.0)	1.614 (41.0)	.314 (8.0)	3.385 (86.0)	4.13 (105.0)	-	HSB	1.98
	4.881 (124.0)	5.629 (143.0)	2.480 (63.0)	.472 (12.0)	4.881 (124.0)	4.13 (105.0)	1.28 (32.5)		
HSC B	4.881 (124.0)	7.007 (178.0)	2.755 (70.0)	.472 (12.0)	6.259 (159.0)	4.13 (105.0)	1.259 (32.0)	HSC	3.96
	4.881 (124.0)	8.818 (224.0)	2.755 (70.0)	.590 (15.0)	7.992 (203.0)	4.13 (105.0)	1.259 (32.0)		
HSN C	4.881 (124.0)	6.496 (165.0)	1.653 (42.0)	.314 (8.0)	5.748 (146.0)	3.38 (86.0)	-	HSN	5.94
	4.881 (124.0)	7.007 (178.0)	2.755 (70.0)	.472 (12.0)	6.259 (159.0)	4.13 (105.0)	1.259 (32.0)		
HSD I	4.881 (124.0)	8.818 (224.0)	2.755 (70.0)	.590 (15.0)	7.992 (203.0)	4.13 (105.0)	1.259 (32.0)	HSD	7.48
	4.881 (124.0)	10.236 (260.0)	2.519 (64.0)	.314 (8.0)	9.251 (235.0)	3.38 (86.0)	1.259 (32.0)		
HDA H	4.881 (124.0)	7.007 (178.0)	2.755 (70.0)	.472 (12.0)	6.259 (159.0)	4.13 (105.0)	1.259 (32.0)	HDA	1.98
	4.881 (124.0)	8.818 (224.0)	2.755 (70.0)	.590 (15.0)	7.992 (203.0)	4.13 (105.0)	1.259 (32.0)		
HDB D	4.881 (124.0)	7.007 (178.0)	2.755 (70.0)	.472 (12.0)	6.259 (159.0)	4.13 (105.0)	1.259 (32.0)	HDB	3.96
	4.881 (124.0)	8.818 (224.0)	2.755 (70.0)	.590 (15.0)	7.992 (203.0)	4.13 (105.0)	1.259 (32.0)		
HDC I	4.881 (124.0)	10.236 (260.0)	2.519 (64.0)	.314 (8.0)	9.251 (235.0)	3.38 (86.0)	1.259 (32.0)	HDC	7.48
	4.881 (124.0)	11.023 (280.0)	2.755 (70.0)	.590 (15.0)	7.480 (190.0)	4.13 (105.0)	1.259 (32.0)		
HTC F	4.881 (124.0)	11.023 (280.0)	2.755 (70.0)	.590 (15.0)	7.480 (190.0)	4.13 (105.0)	1.259 (32.0)	HTC	5.06
HTD G	4.881 (124.0)	11.023 (280.0)	2.755 (70.0)	.590 (15.0)	7.480 (190.0)	4.13 (105.0)	1.259 (32.0)	HTD	7.92

NOTE:
 1. DIMENSIONS ARE IN INCHES EXCEPT DIMENSIONS () ARE IN MM.
 2. .188 (4.8) HOLES FOR CUSTOMER MTG.

For Additional Information, please visit
us.tdk-lambda.com/lp/products/h-series.htm